

ALLIANCE

SLIDING GATE

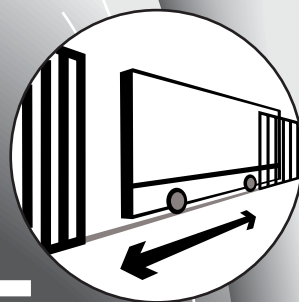

Installation

INSTRUCTIONS

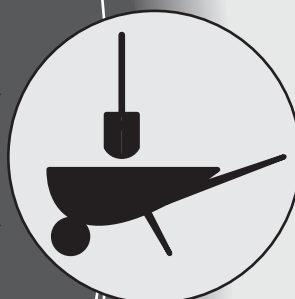

Use

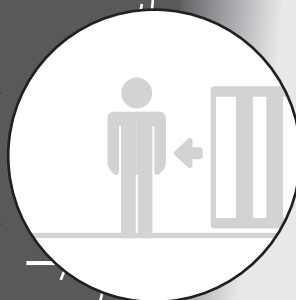

Maintenance



Care

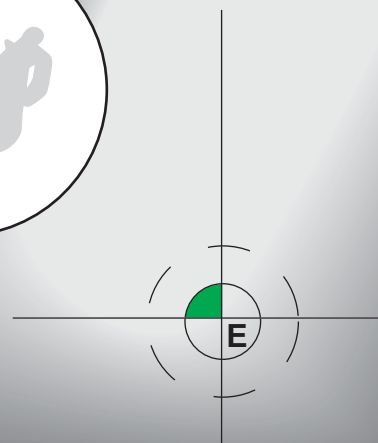

ALLIANCE Sliding gate EN 01 - 05 2005 Edition INSTALLATION

INTRODUCTION

All the information contained in this specification sheet including pictures and figures is the property of DIRICKX. Total or partial reproduction without permission of DIRICKX is illicit.

DIRICKX might modify components of the material at anytime and without prior notice. The content of the sheets can also be subject to modifications.

All the sheets, including this one, are adapted exclusively to the material they are delivered with.

REGULATION

This manual was edited in respect with the recommendation of the European Standard **NF EN 12635** concerning the gates that equip the industrial and business buildings and garages in accordance with European Standard **EN 292-2** that specifies that is essential to provide the installer and the user with the complete documentation attached to the material.

**COMPLETE AND SAFE FUNCTIONING IS ENSURED ONLY IF
A SKILLED INSTALLER EXECUTES THE INSTALLATION AND
MAINTENANCE IN RESPECT WITH THE INSTRUCTIONS
AND THE VALID REGULATIONS.**

PICTOGRAMS AND SIGNIFICATION

This specification sheet contains pictograms warning the installer and the user about the points to be considered to ensure the correct installation, use, service and maintenance operations.

It is important to follow the information accompanying the pictograms to ensure the security of installer and user but also the good functioning of the material.



**DANGER PANEL FOLLOWED BY THIS FRAME
INDICATES VERY IMPORTANT INFORMATION
TO TAKE INTO CONSIDERATION.**



Timing to respect during to the installation procedure.



Refer to the concerned documentation.



Risk of injury, heavy material.



*Employment of security equipment
(gloves, helmet, goggles...).*



Use of lifting machine recommended.



Packing and storage.



*Required skills:
qualified person according to the
Standard EN 12635.*



*Required skills:
professional installer according to the
Standard EN 12635.*



WARNING



NF EN 13241-1 Standard

THE INSTALLER IS OBLIGED TO HAND IN TO USER THE USAGE,
MAINTENANCE AND SERVICE INSTRUCTIONS.

S u m m a r y

	Pages
1 - Description of the gate	4
2 - Reception, handling and storage	5
2-1 Packing list	5
2-2 Complaint	5
2-3 Handling and storage	6
3 - Installation	7
3-1 Opening direction	7
3-2 Security	7
3-3 Setting the groundwork	8
3-4 Embedding the inserts	9
3-5 Placement and positioning	10 to 12
4 - Pre-motorisation process	13
4-1 Civil engineering	13
4-2 Embedding the inserts	14
4-3 Disassembling the elements of the manual gate	15
5 - Reception of work	16
5-1 Control for reception of work	16
5-2 Waste disposal	16
6 - Residual risks	17

MANUAL
VERSION

PRE-MOTORISATION
PROCESS



DIRICKX

HAUTE CLOTURE FRANÇAISE

1 Description of the gate

Manual ALLIANCE sliding gate

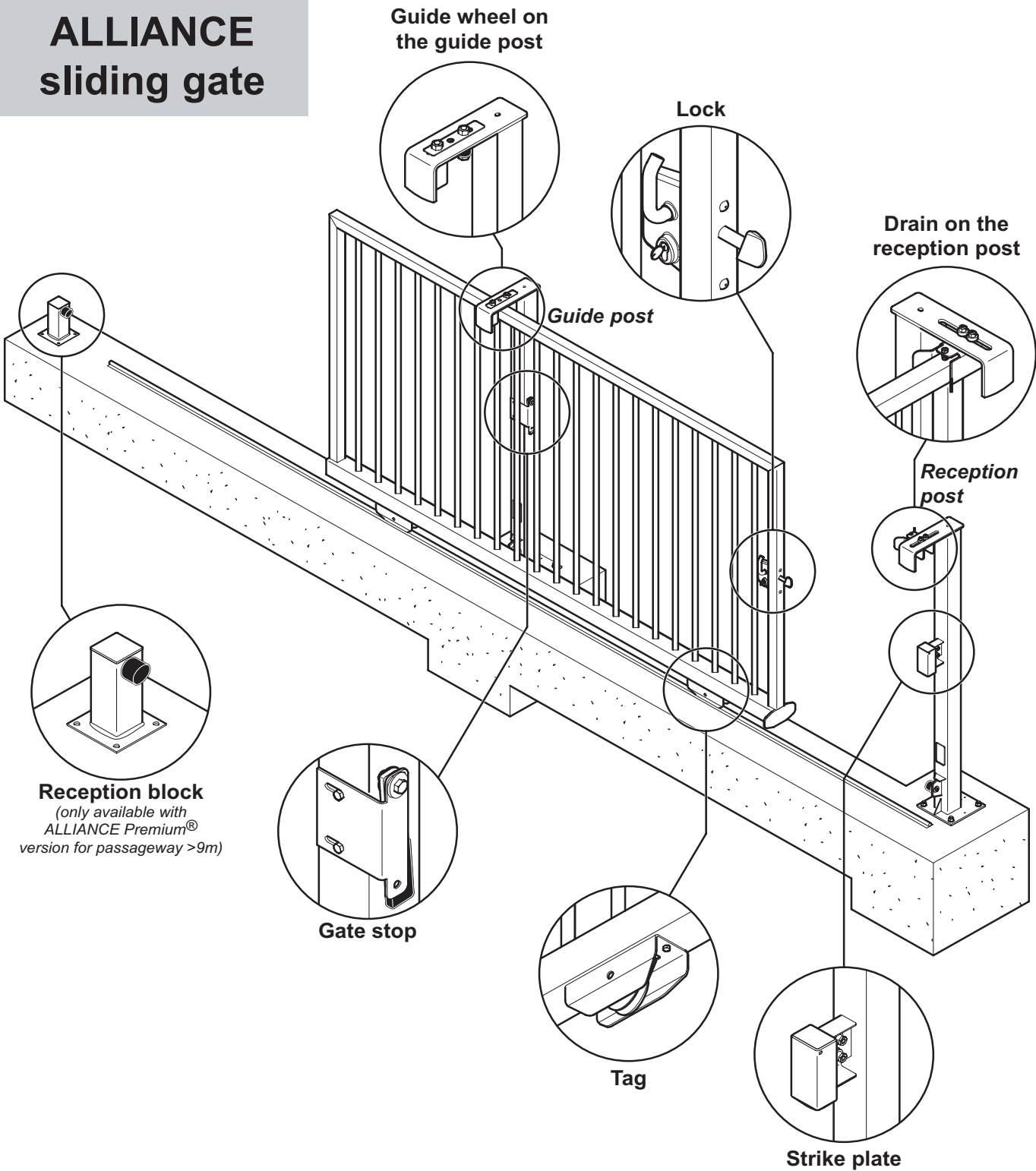

Presented model: ALLIANCE Classic® sliding gate

2 Reception, handling and storage

2-1 Packing list

You have ordered an ALLIANCE sliding gate. It is a sideways-shifting gate sliding on a rail guide concreted in the ground. It is composed of one leaf, one rail and two posts designed to be fixed into concrete footings.

The reception block is delivered only for ALLIANCE Premium Sliding gates that have a passageway from 9m up.

2-2 Complaint

Please check the material right after reception. If you notice anomalies (missing component...) contact DIRICKX at the address stated at the end of this notice.

According to our standard conditions of sale, the complaints concerning the quantity, the weight and the dimensions, and the quality related to chemical and physical characteristics are accepted only if they are notified in writing **up to 15 days after the delivery of the goods and before any transformation.**

ALLIANCE sliding gate:

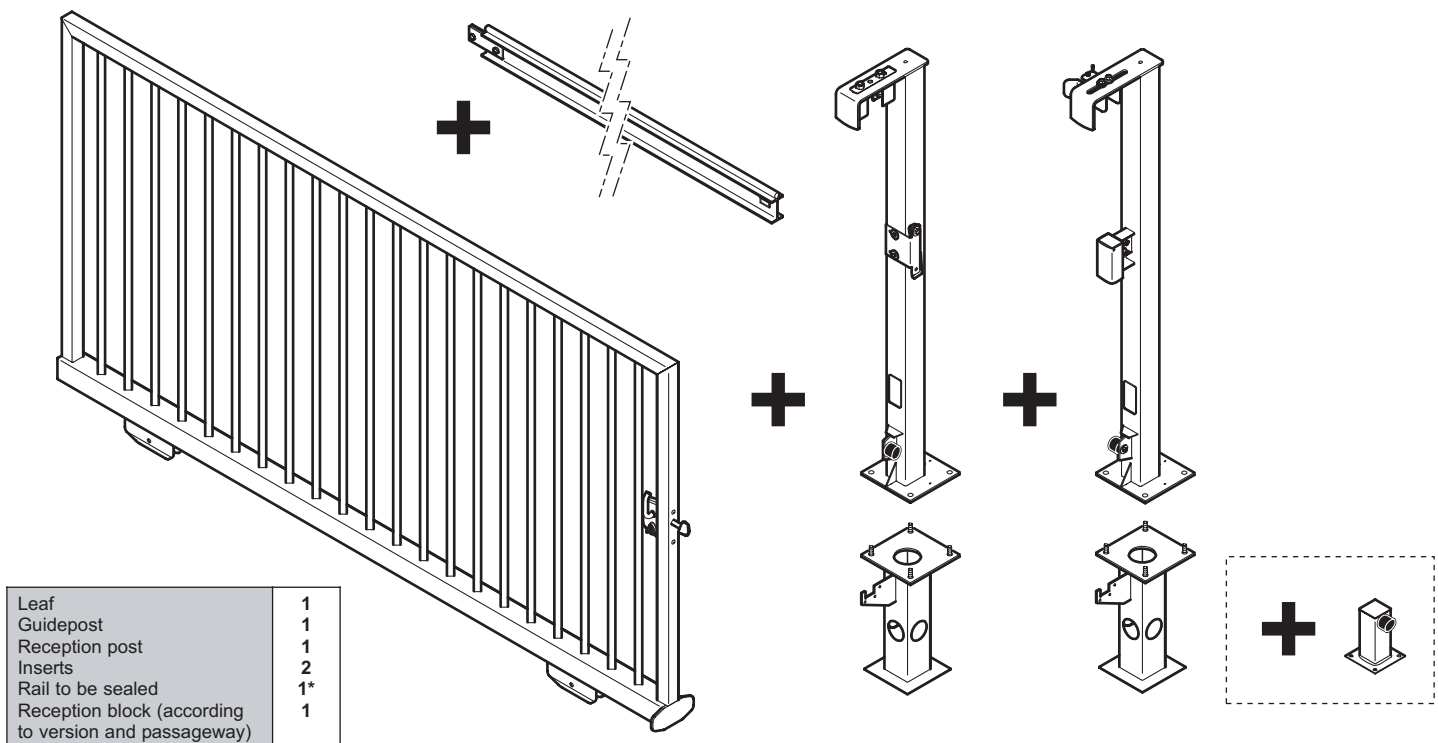

* number of variable elements according to passageway

2 - Reception, handling and storage

2-3 Handling and storage

In order to handle the material in the best security and installation conditions, the use of lifting machine is compulsory. The choice of this machine will be determined by the volume and weight of the components.



The components are heavy and voluminous so that every handling requires the employment of security equipment (helmet, gloves, goggles...).



The specifications (length, height, weight) are notified in the **order confirmation** and in the **civil engineering and installation plan** (cf. *weights table*).

To avoid any damage, it is recommended to protect each element from the beginning of the handling operation.

During the use of the lifting machine the following suspension is recommended:

During unloading the suspension must be done in 2 points at the same distance of the middle of the gate. (cf. **fig. 1**).

During handling of the gate the suspension must be done in 2 points, with an angle of maximum 60 degrees (cf. **fig. 2**).

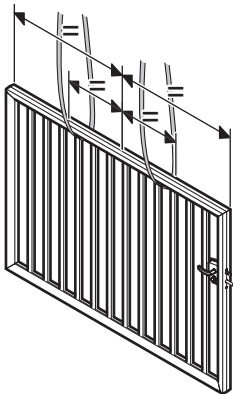

1 - Unloading

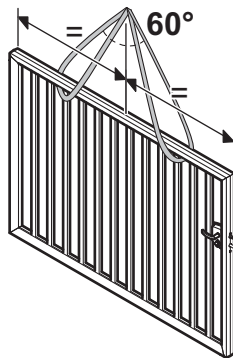

2 - Handling

Store the material in a public inaccessible place. Place the leaves in a plane position and protect the elements at the supporting points with polyester or equivalent props.



BAD STORAGE CONDITIONS MAY HARM THE SECURITY OF THE NEIGHBOURING PERSONS AND CAUSE FUNCTIONAL AND AESTHETIC DAMAGE.

TYPE	MAXIMUM WEIGHT	
	<i>Per leaf</i>	<i>Per post</i>
ALLIANCE Classic®	210 Kg	35 Kg
ALLIANCE Premium®	560 Kg	60 Kg

Footnote:

ALLIANCE Classic sliding gate, passageway 6m, height 2m, grilled filling
ALLIANCE Premium sliding gate, passageway 12m, height 2m, grilled filling

3 Installation

3-1 Opening direction

The opening direction indicated in the purchase order can be modified at installation for manual versions. The opening direction specified in the purchase order is definitive for the motor-driven versions.



ALWAYS PLACE YOURSELF IN THE EXTERIOR OF THE SITE TO INDICATE THE OPENING DIRECTION.

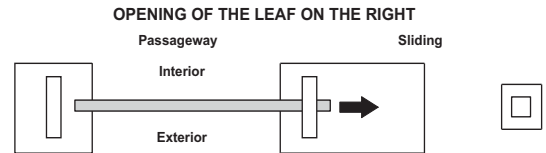
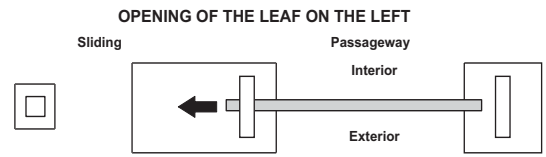

Check out if the opening direction corresponds to the ordered one before the installation.

3-2 Security

FOR THE ENCLOSURES SITUATED NEAR A GATE OR AN ENTRY:

The installer must protect the access to the sliding area of the gate according to the Standard **NF EN 12635** (Gates equipping industrial and business buildings and garages – Installation and use). The objective of this norm is to eliminate the risk of crashing, cutting or interception.

Thus the enclosure has to be placed at a secure distance from the leaf in motion (cf figure below).

This security distance takes into account the parts of human body that might be exposed to danger according to the Standard **NF EN 294** (security distances to avoid harm of danger of the upper parts of the human body) and the dimension of enclosure grid placed in the extension of the gate (see the opposite table).

SECURITY DISTANCE	SLIDING ENCLOSURE	
	DIMENSION OF THE GRID	PRODUCT EXAMPLE
≥ 120mm	from 20 to 30mm	ARAVIS**
≥ 200mm	from 30 to 40mm	Square grid**
≥ 850mm	> 40mm	AXIS®

**SMALL GRIDS CAN BE SET OUT IN TIERED ROWS USING AXIS® PANELS.

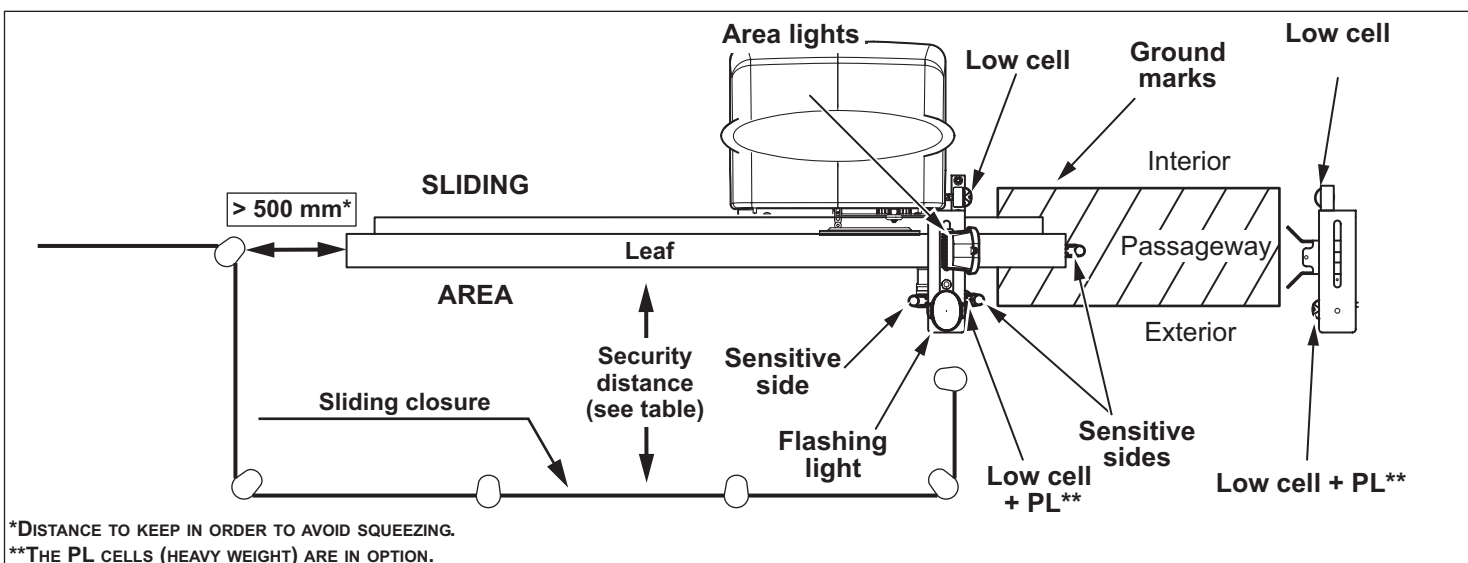

*DISTANCE TO KEEP IN ORDER TO AVOID SQUEEZING.

**THE PL CELLS (HEAVY WEIGHT) ARE IN OPTION.

3 - Installation

3-3 Setting the groundwork

The installer has to prepare a concrete frame. It is **necessary** to consult **the civil engineering and installation plan** delivered after the purchase order.



TAKE INTO CONSIDERATION THE SLIDING AREA OF THE GATE.

- Determine the final position of the gate and define the foundation.

- Make a **perfect flat and levelled excavation**.



THE INSTALLER IS RESPONSIBLE FOR THE DIMENSIONING AND FOR THE QUALITY OF THE CONCRETE FOOTINGS.

- Prepare the foundation.

- Put a metal lattice into the foundation.

- Align a cord between the passageway area and the sliding area.



**FLAT SITE:
THIS TYPE OF MATERIAL HAS TO BE PLACED ON A PERFECT FLAT GROUND.**

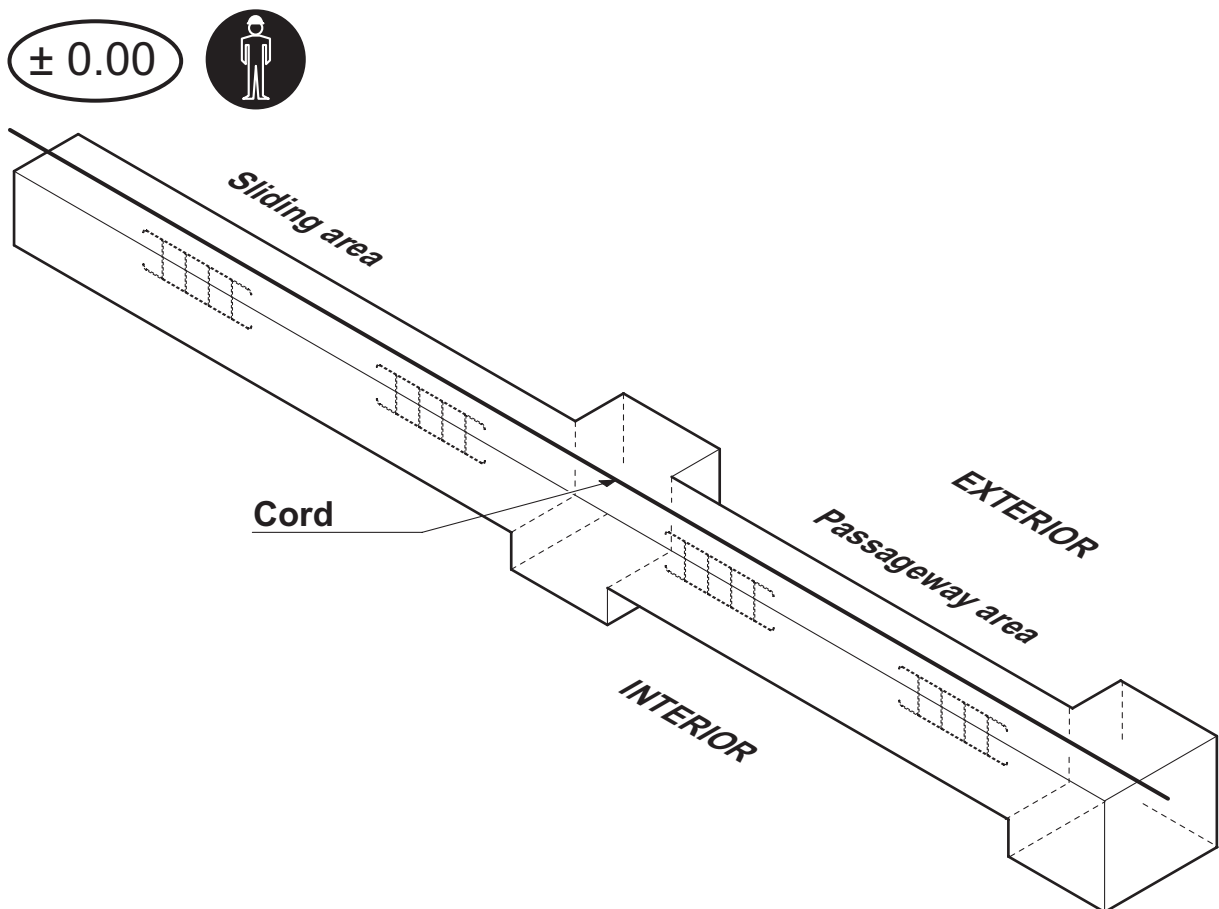

3 - Installation

If you envisage motorising your gate later do not forget to plan a 500mm over length of the leaf.

For the installation of a motor-driven gate see page 13.

3-4 Embedding the inserts

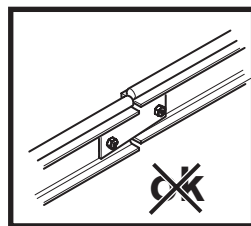
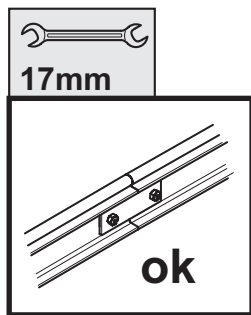

- Place and fix the inserts as indicated in the civil engineering and installation plan.

- Check the 0 level.

- Verify the alignment by using a cord.

- Pour in the concrete up to the rail supports level.

- Control the 0 level.

- If the opening is larger than 6m connect the rails in between them with connection planks. Make sure the alignment is perfect.

- Place the rail and estimate 5cm overlap on the insert, on the reception post side.

- Fix the rail as indicated in the civil engineering and installation plan.

- Pour the concrete, and then clean up the rail and plates.

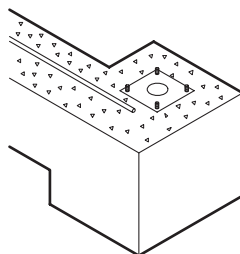
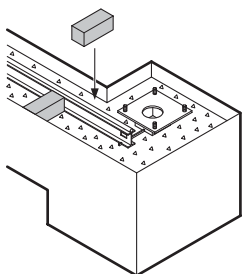
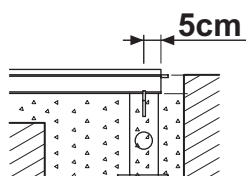
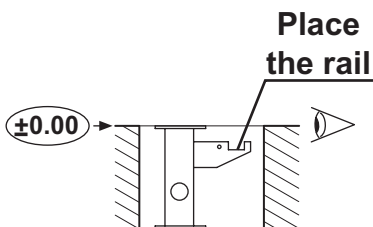

**MARK AND PROTECT
THE CONSTRUCTION AREA.**



3 - Installation

3-5 Placement and positioning

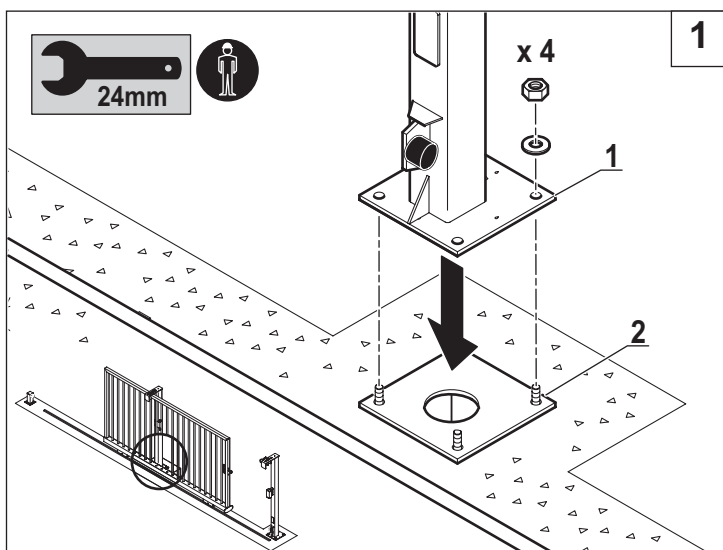

1

Placement of the guidepost:

Put the guide post (rep. 1) on its insert (rep. 2) using nuts and discs.

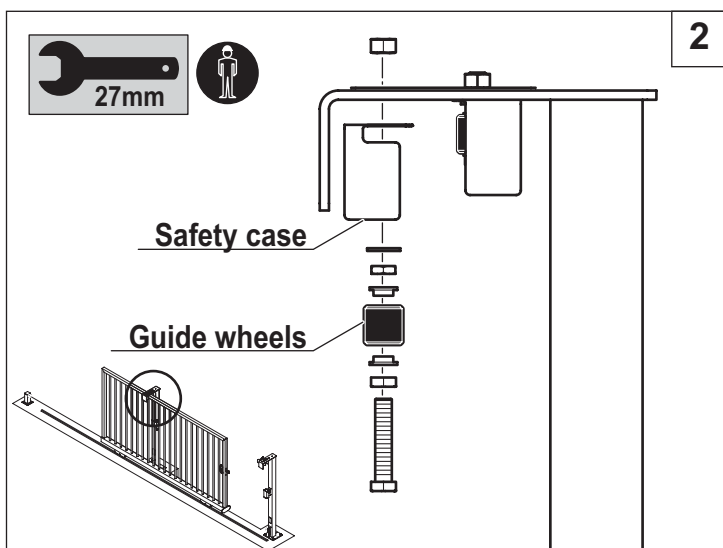

2

Placement of the leaf:

Remove the wheel from the guidepost before fixing the leaf.

Use the lifting machine to ensure the best security and installation conditions for the handling (cf page 6).

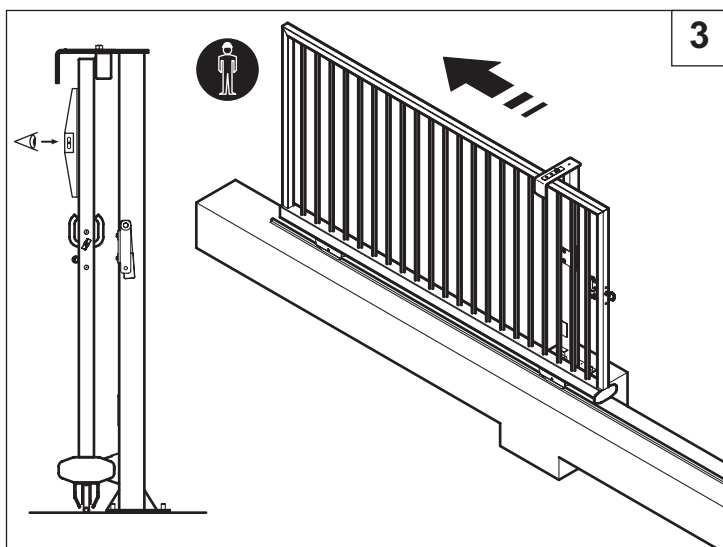

3

Set the leaf on the rail on the passageway side and make it slide to the sliding area.

Hang on the leaf.

Fix the wheels again (according to the previous paragraph).

Control the verticality of the leaf before blocking the wheels.



DO NOT HANDLE THE LEAF WITHOUT THE RECEPTION POST.

3 - Installation

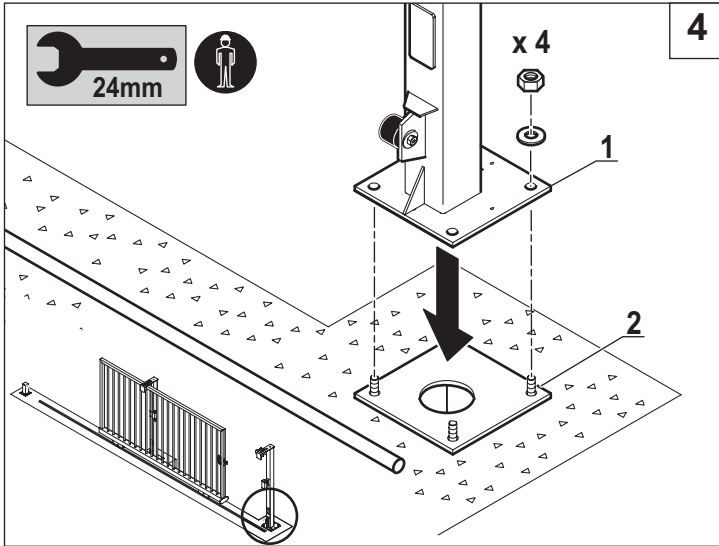

4

Placement of the reception post:

Put the reception post (rep. 1) on its insert (rep. 2) using nuts and discs.

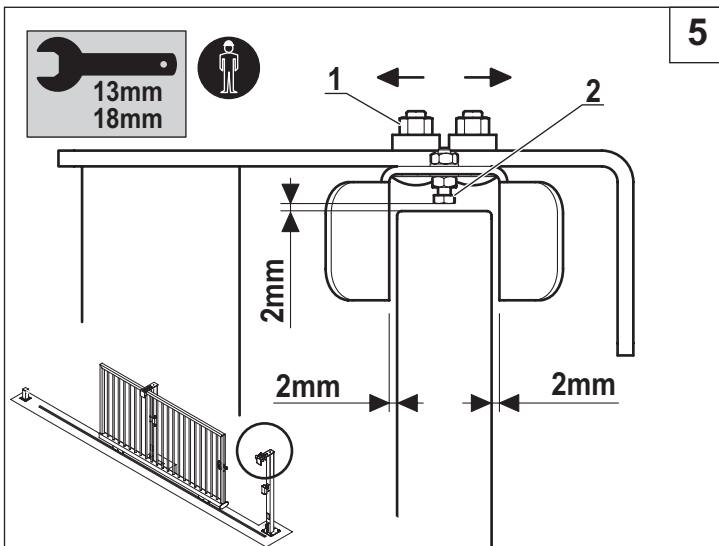

5

Reception bottleneck:

Adjust the reception bottleneck using screws (rep. 1) to obtain a 2mm gap on each side of the leaf.

Adjust the bolt (rep. 2) under the reception bottleneck using a 13mm key to reduce the gap between the leaf and the bottleneck (closed leaf).

The bolt must not touch the leaf.

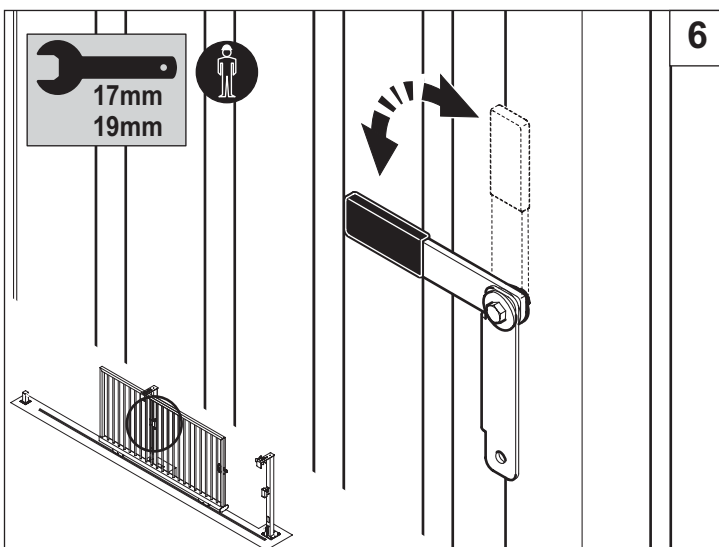

6

Retaining stop:

Check if the retaining stop on the guidepost is functional. Adjust it using a nut if necessary.

To secure the opening and avoid any uncontrolled movements, the blocking handle is activated between the crossbars of the leaf.

3 - Installation

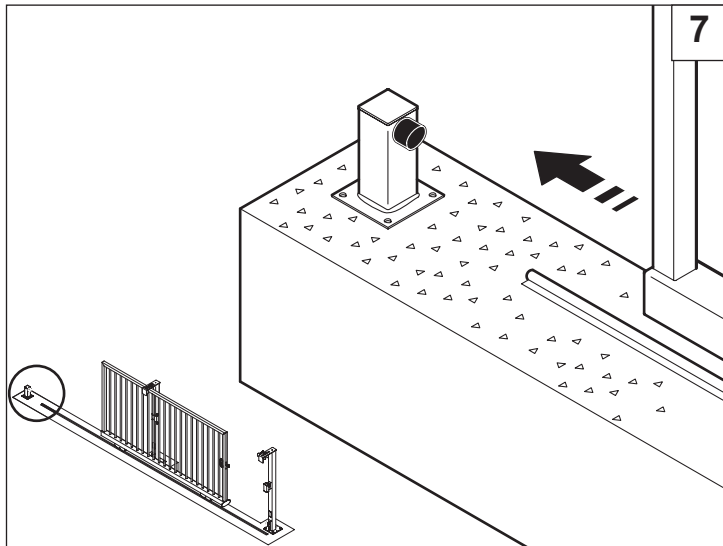

7

Reception block (Available only for ALLIANCE Premium® version that have the passageway >9m):

Open the leaf completely.

Align the rail with the post.

Connect the support block with the beam.

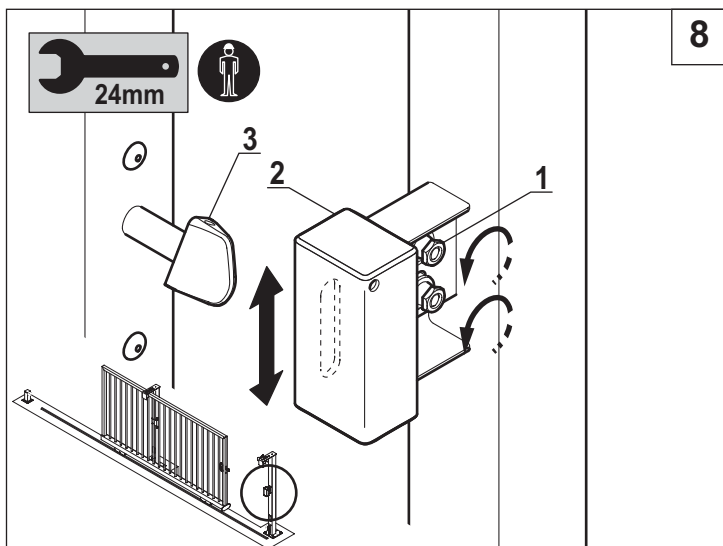

8

Adjusting the catch:

Release the screws (rep. 1) of the catch (rep. 2).

Drag the leaf and place the catch to a higher position so that the arrow (rep. 3) can enter into the catch.

Screw and tighten (rep. 1) until the breakdown of the self-breaking screws.

4 - Pre-motorisation process

4-1 Civil engineering

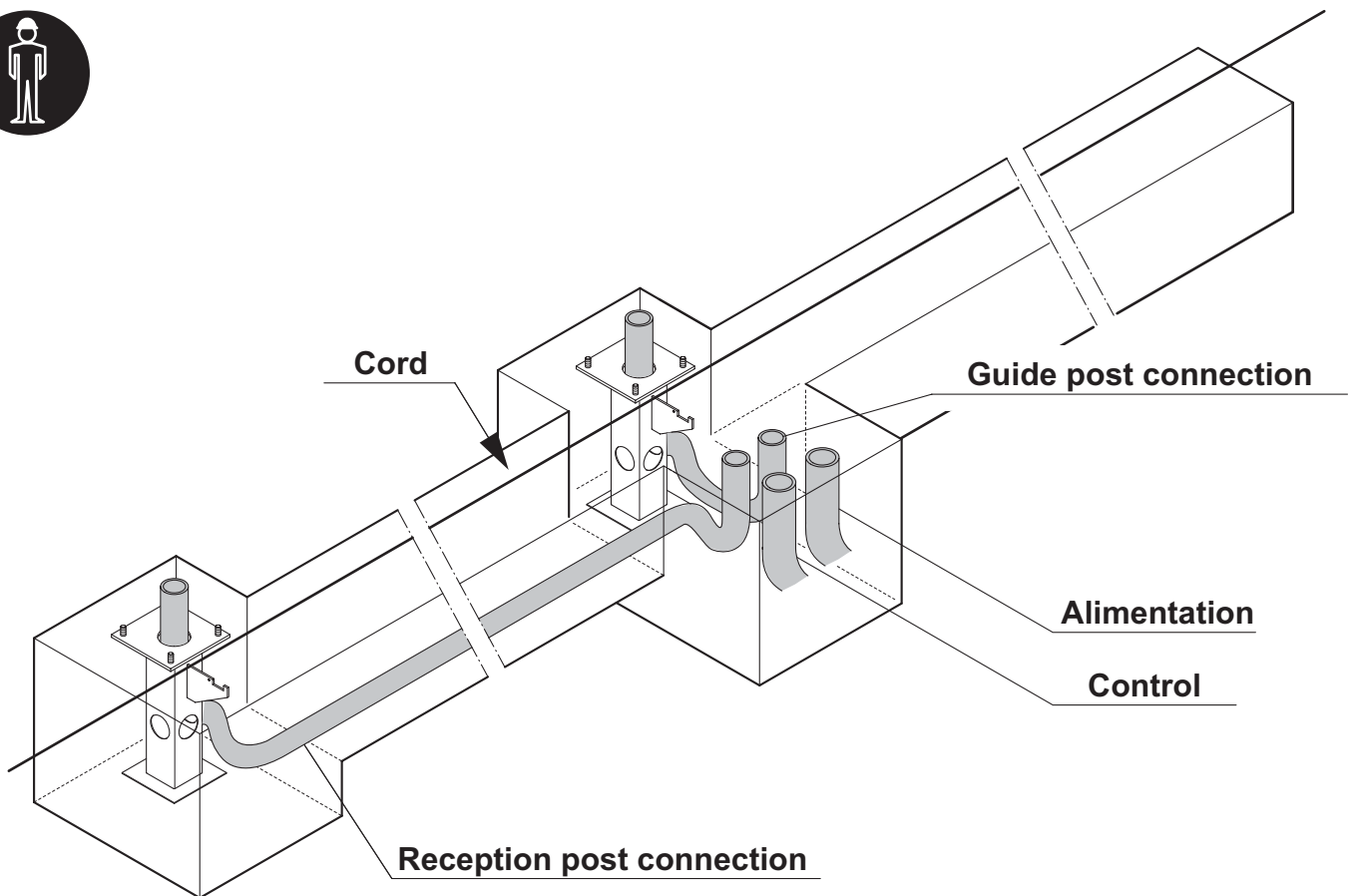

The installation procedure for a motor-driven gate or planned to be motorised is similar to the installation of the manual gate (cf. **pages 7 to 12**), but it is necessary to place the sleeves while carrying out civil engineering installation as well as the connection of the electric elements.



REFER TO CIVIL ENGINEERING AND INSTALLATION PLAN IN ORDER TO DIMENSION AND PLACE THE SLEEVES.

4 - Pre-motorisation process

4-2 Embedding the inserts

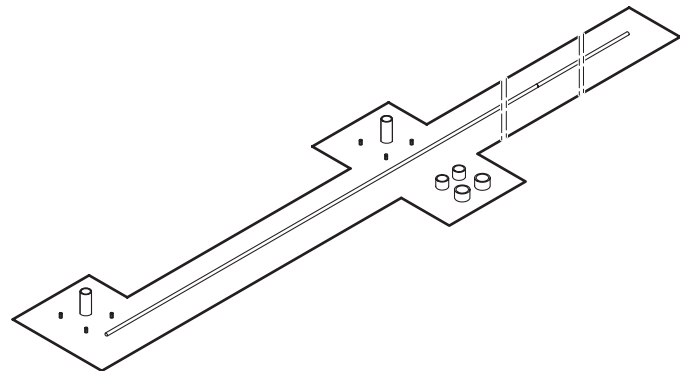
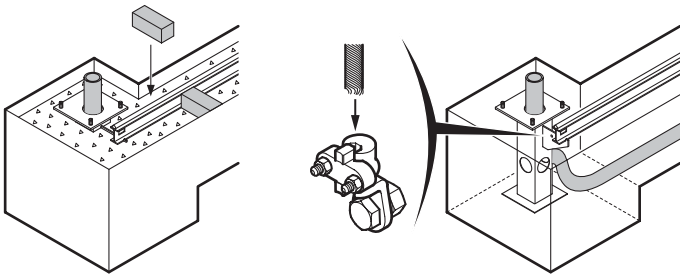
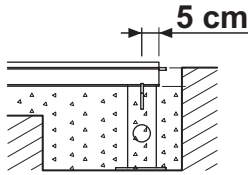
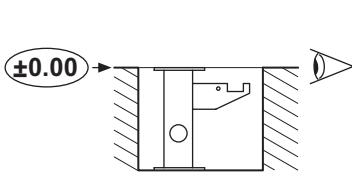
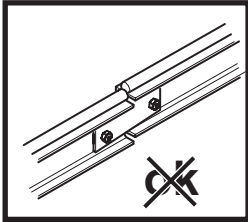
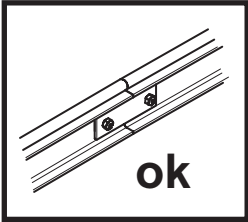
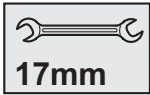

Civil engineering:

- Place and fix the inserts.
- Check the 0 level.
- Align and position the sleeves.
- Pour in the concrete up to the rail locator.
- Control the verticality and the alignment.
- Place the rail into the rail locator. Settle the rail an estimate 5cm overlap on the insert, on the reception post side.
- Fix the rail.
- Check the verticality of the structure.
- Pour the concrete, and then clean up the rail and plates.

For fixing the leaf and adjustments see **page 11**.

! START TO SET UP THE METAL PARTS INTO THE GROUND.

! MARK AND PROTECT THE CONSTRUCTION AREA



Consult the attached notice to run the automatic service.



4 - Pre-motorisation process

4-3 Disassembling the elements of the manual gate

In case of motorisation of your gate you have to dismantle certain elements. These elements are useless and dangerous after the motorisation thus they have to be replaced with elements adapted to the use of a motor-driven gate.

Please follow the dismantle protocol before starting the motorisation of your gate.

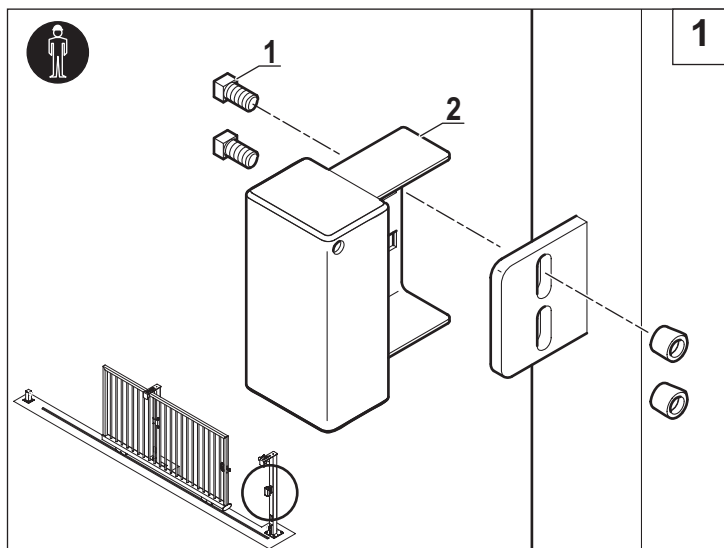

1

Dismantle the catch:

Precisely take away the heads of the screws (rep. 1).
Protect the reception post during this operation.

Pull out the catch from its support (rep. 2).

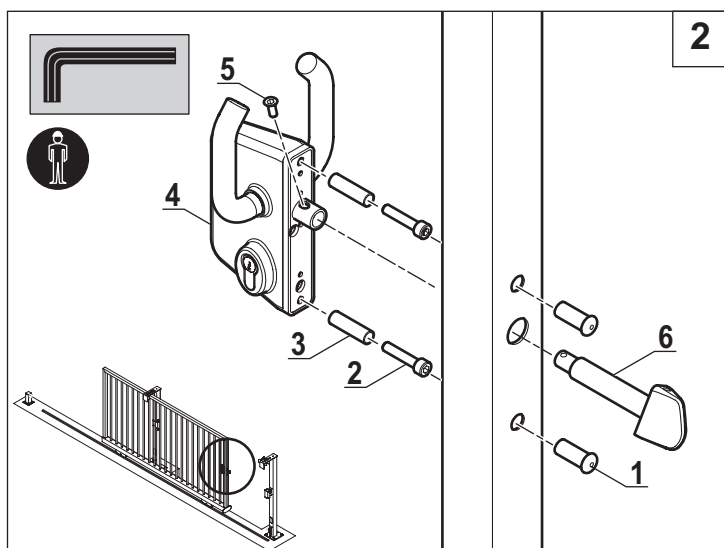

2

Dismantle the lock:

Remove the shields (rep. 1).

Release (rep. 2) and remove the screws and the braces (rep. 3) while holding the lock (rep. 4).

Move the lock to the position where the arrow (rep. 6) pulls against the stand of the leaf.

Remove the arrow (rep. 5) and take away the lock.



TAKE CARE NOT TO DROP THE BRACES INTO THE BASEMENT.

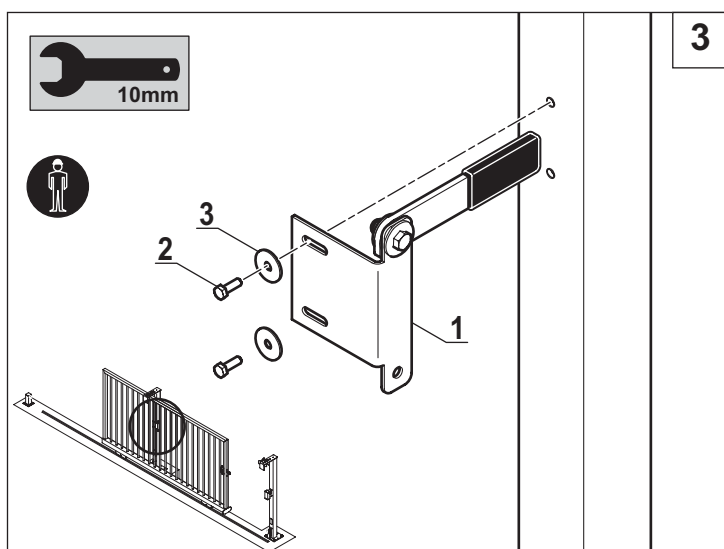

3

Dismantle the gate stop:

Release (rep. 2) and remove the gate stop (rep. 1) and the discs (rep. 3) situated on the guidepost.

Once these phases completed, you have to start quickly the motorisation of your gate.



5

Reception of work

5-1 Control for reception of work

When the material is installed please test the fix and mobile elements to verify the good functioning of the gate before delivering it to the user.

Make sure that:

- The gate slides without excessive effort and without friction.
- The elastomer stops are properly installed in order to soften the shutting of the gate.
- The lock is functioning and keeps the leaf closed (make a turn over with a key).
- The centre blocks keep the leaf blocked when it is opened.
- There are no blocking zones.
- The blocks on the sideways – when opening or closing the gate – are effective.
- The ground marks are clear.

5-2 Waste disposal

Once the installation is done and the controls are completed, remove all the covers and residues of installation.

Throw away the waste into appropriated places (junkyard...)



LEAVE THE SITE CLEAN.



6

Residual risks

Certain parts of the gate cannot be protected and represent therefore risk zones.

Residuary risks are indicated on the gate by stickers designed to inform the user on the type of the risk he is exposed to when entering into contact with certain parts of the gate.

For your security, follow the recommendations concerning your gate.

Signification of warning signs for residual risks



Indicates a “residual” risk of getting your hands pinched or squeezed between the fixed part of the installation and the mobile element.



Indicates a “residual” risk of getting your feet pinched or squeezed between the fixed part of the installation and the mobile element.



Indicates a “residual” risk of stumbling.



Indicates a “residual” risk of interception by the moving pieces.



Indicates a “residual” risk of electric shock.